

SIZP...S(d 4.83~25.4)

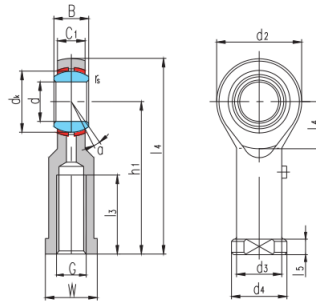

Seleccione Consulta	Número de rodamiento	Dimensiones (mm)														Clasificación de carga básica (kN)		Peso corazón kg		
		dk	segundo	d _k	C ₁ máximo	d ₂	G	h ₁	l ₃ min	l ₁	l ₅	l ₇	W	d ₃	d ₄	rs min	un°		cr	
SIZP4S ⁽¹⁾	4.83	7.92	11.1	6.35	15.88	10-32	26.97	14.27	34.93	4.75	9	7.92	7.54	10.31	0.3	10	3.4	4.6	0.015	
SIZP4S ⁽¹⁾	0.19	0.312	0.437	0.25	0.625	10-32	1.062	0.562	1.375	0.187	0.354	0.312	0.297	0.406	0.012	10	3.4	4.6	0.015	
SIZP6S ⁽¹⁾	6.35	9.53	12.7	7.14	19.05	1/4-28	33.32	19.05	42.85	4.75	10.5	9.53	9.15	11.91	0.3	13	4.5	7.7	0.025	
SIZP6S ⁽¹⁾	0.25	0.375	0.5	0.281	0.75	1/4-28	1.312	0.75	1.687	0.187	0.413	0.375	0.36	0.469	0.012	13	4.5	7.7	0.025	
SIZP7S	7.94	11.1	15.88	8.74	22.23	5/16-24	34.93	19.05	46.02	4.75	11.7	11.1	10.72	12.7	0.3	10	6.9	8.4	0.036	
SIZP7S	0.3125	0.437	0.625	0.344	0.875	5/16-24	1.375	0.75	1.812	0.187	0.461	0.437	0.422	0.5	0.012	10	6.9	8.4	0.036	
SIZP9S	9.53	12.7	18.26	10.31	25.4	3/8-24	41.28	23.8	53.98	6.35	12.3	14.27	13.89	17.45	0.6	9	9.4	10	0.061	
SIZP9S	0.375	0.5	0.719	0.406	1	3/8-24	1.625	0.937	2.125	0.25	0.484	0.562	0.547	0.687	0.024	9	9.4	10	0.061	
SIZP11S	11.11	14.27	20.62	11.1	28.58	7/16-20	46.02	26.97	60.33	6.35	14	15.88	15.49	19.05	0.6	11	11	13	0.081	
SIZP11S	0.4375	0.562	0.812	0.437	1.125	7/16-20	1.812	1.062	2.375	0.25	0.551	0.625	0.61	0.75	0.024	11	11	13	0.081	
SIZP12S	12.7	15.88	23.81	12.7	33.32	1/2-20	53.98	30.15	70.64	6.35	16.2	19.05	18.67	22.23	0.6	9	15	19	0.133	
SIZP12S	0.5	0.625	0.937	0.5	1.312	1/2-20	2.125	1.187	2.781	0.25	0.638	0.75	0.735	0.875	0.024	9	15	19	0.133	
SIZP15S	15.88	19.05	28.58	14.27	38.1	5/8-18	63.5	38.1	82.55	7.92	18.2	22.23	21.84	25.4	0.6	11	20	21	0.190	
SIZP15S	0.625	0.75	1.125	0.562	1.5	5/8-18	2.5	1.5	3.25	0.312	0.717	0.875	0.86	1	0.024	11	20	21	0.190	
SIZP19S	19.05	22.23	33.32	17.45	44.45	3/4-16	73.03	44.45	95.25	7.92	20.9	25.4	25.02	28.58	0.6	10	29	29	0.285	
SIZP19S	0.75	0.875	1.312	0.687	1.75	3/4-16	2.875	1.75	3.75	0.312	0.823	1	0.985	1.125	0.024	10	29	29	0.285	
SIZP25S	25.4	34.93	47.63	25.4	69.85	5/4-12	104.78	53.98	139.7	11.1	33.1	38.1	37.72	44.45	0.6	14	60	101	1.00	
SIZP25S	1	1.375	1.875	1	2.75	5/4-12	4.125	2.125	5.5	0.437	1.303	1.5	1.485	1.75	0.024	14	60	101	1.00	